

WPS : See drawing PEDC007V0

Material according to design drawing PEDC007V0

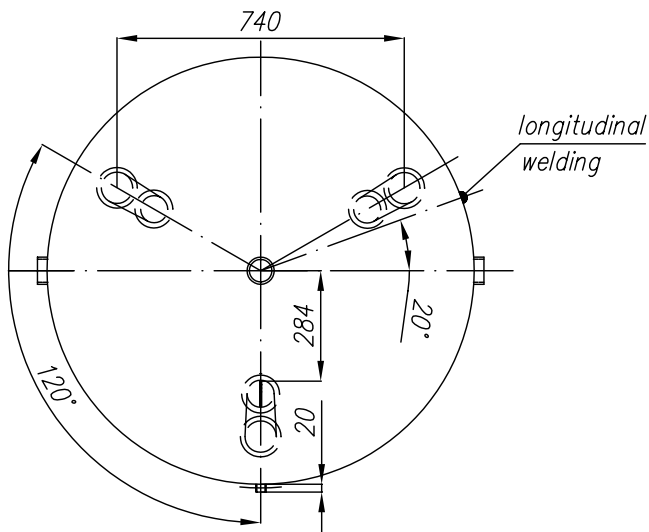
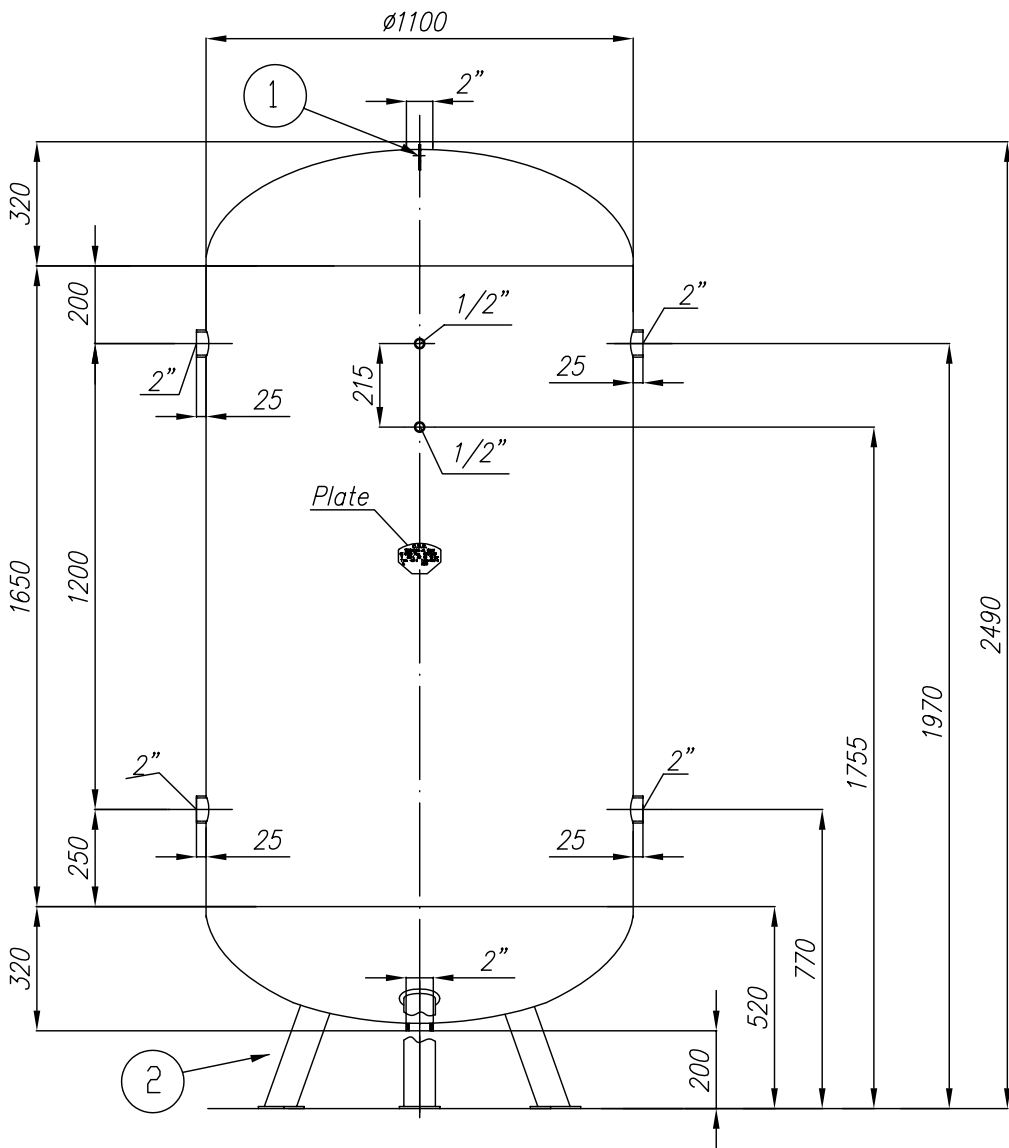

C.S.C. S.r.l.
 TERRUGGIA AL ITALY
 € 0044 PS 12 Bar
 V 2000 L AIR PT 17.1 Bar
 T min -10° C T max +50° C
 TYPE S20V012 MM-YY
 N.F.

① Eyebolt (q.ty 1)

code c.s.c.: CXXGOLF/02

② Leg (q.ty 3)

code c.s.c.: CXXGAMBTUBO/02

SURFACE TREATMENTS

RAW

TOLERANCES, IF NOT INDICATED, ACCORDING TO:

SCALE 1:20

SHEET A4

DRAWING N.



REASON OF REVISION

APPROVED

DATE

SIGN.

REVIEWED

25/12/2005

B. RAGONESE

DATE

SIGNATURE

Litres 2000 - 12 bar - verticale - PED

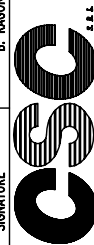

TERRUGGIA (AL) - ITALY

SST.200012VEF

REV. 0