

Siłownik okrągły zagniatany PSOP ISO 6432

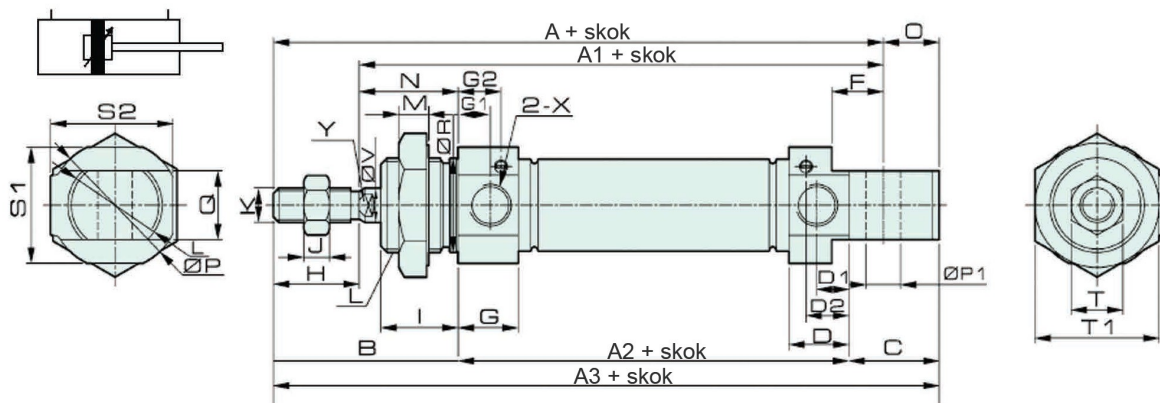

Ø mm	A	A1	A2	A3	B	C	D	D1	D2	F	G	G1	G2	H	I	J
16	98	82	55	111	37	19	10,5	6	7	9	10.5	6	7	16	16	5
20	115	95	64	128	43	21	14	7.5	10	9	14	7.5	10	20	16	6
25	126	104	66	137	50	21	15	8	10.5	12	15	8	10.5	22	22	6
Ø mm	K	L	M	N	O	P	P1	Q	R	S1	S2	T	T1	X	V	Y
16	M6x1	M16x1.5	6	21	13	21	6	12	16	19	19	10	24	M5x0.8	6	5
20	M8x1.25	M22x1.5	7	23	13	30	8	16	22	27	28.5	12	29	1/8"G	8	6
25	M10x1.25	M22x1.5	7	28	11	30	8	16	22	27	28.5	17	29	1/8"G	10	8

Ciśnienie pracy	1 - 10 bar
Medium	sprężone powietrze wg ISO 85731:2010 [7:4:4]
Temperatura pracy	-20°C do +70°C
Amortyzacja	pneumatyczna, regulowana
Pokrywy	aluminium
Tłoczysko	stal nierdzewna
Tuleja	stal nierdzewna
Uszczelnienia	PU/NBR
Standard	ISO 6432